

YOKO-01

Acoustics

Sillón 1 plaza / 1-seater armchair / Fauteuil 1 place

YOKO-01

ES

DESCRIPCIÓN

1. Sillón tapizado y acolchado con estructura de madera. Patas de estructura tubular metálica

ESTRUCTURA

2. Asiento ergonómico tapizado
3. Estructura tubular metálica de Ø16mm pintada de negro
4. Goma antideslizante en las patas

EN

DESCRIPTION

1. Upholstered and padded armchair with wooden structure. Tubular metal frame legs

STRUCTURE

2. Ergonomic upholstered seat
3. Ø16mm metal tubular structure painted black
4. Non-slip rubber on the legs

FR

DESCRIPTION

1. Fauteuil rembourré avec structure en bois. Pieds tubulaires en métal

STRUCTURE

2. Siège rembourré ergonomique
3. Structure tubulaire en métal Ø16mm peinte en noir
4. Caoutchouc antidérapant sur les pieds



COLOR · COLOR · COULEUR

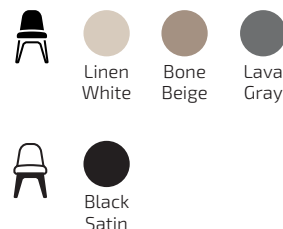

EMBALAJE · PACKAGING · EMBALLAGE



Cantidad de bultos
Pack quantity
Nombre de paquets

1

A. 71x68x59cm

DETALLES · DETAILS · DÉTAILS



MEDIDAS · MEASUREMENTS · MESURES



67 cm



79 cm



71 cm



13,5 Kg



16,5 Kg

PESO · WEIGHT · POIDS

YOKO-01

Acoustics

Medidas asiento / Seat dimensions / Dimensions assise

YOKO-01

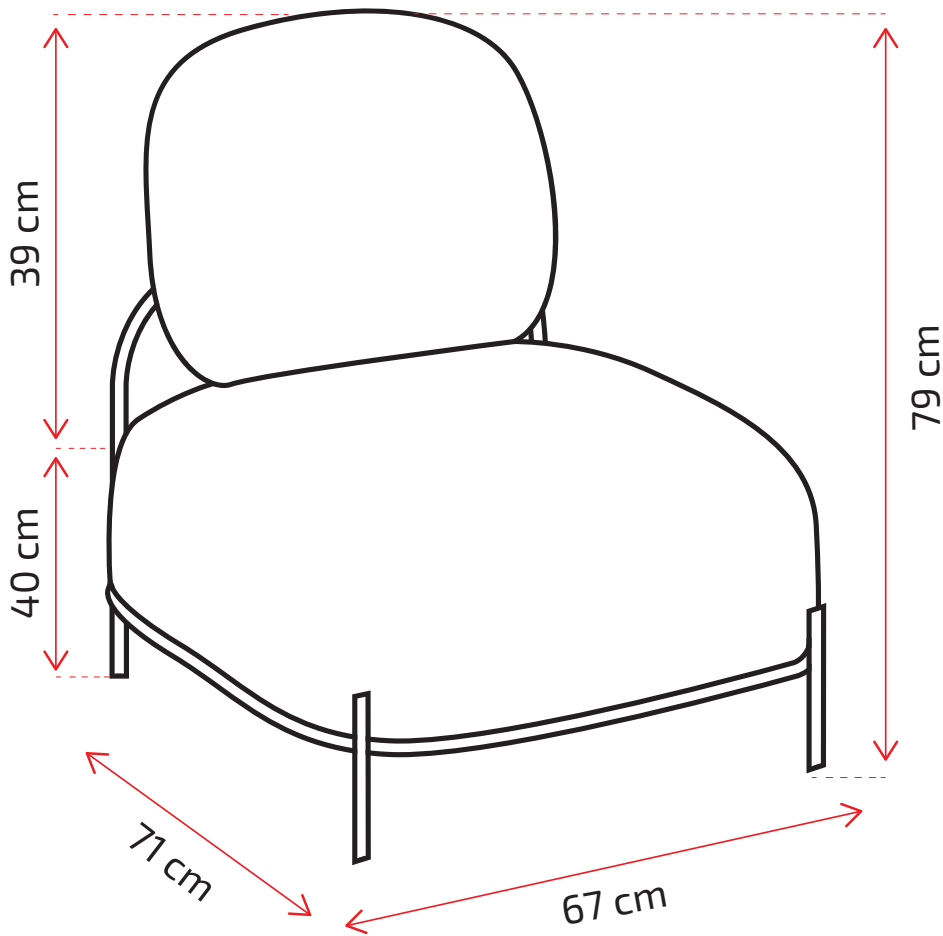

Combinaciones de color / Color Combinations / Combinaisons de couleurs



YOKO-01/98/134



Linen White



Black Satin

YOKO-01/98/135



Bone Beige



Black Satin

YOKO-01/98/136



Lava Gray



Black Satin

YOKO-01

Acoustics

Instrucciones de montaje / Assembly instructions / Notice de montage

YOKO-01

1. x1pc

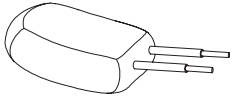

2. x1pc

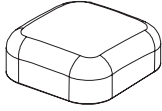

3. x1pc

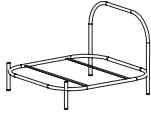

4. x2+1pc



5. x4+1pc

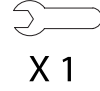
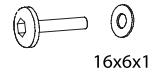

X 1

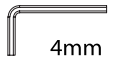

4mm

1

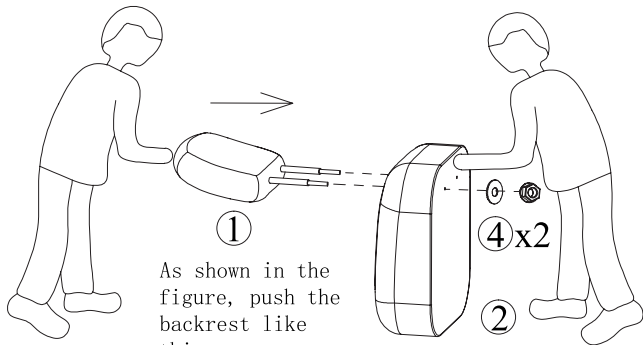
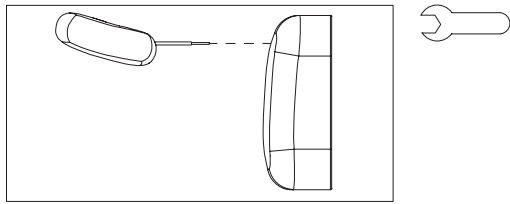

As shown in the figure, push the backrest like this.

2

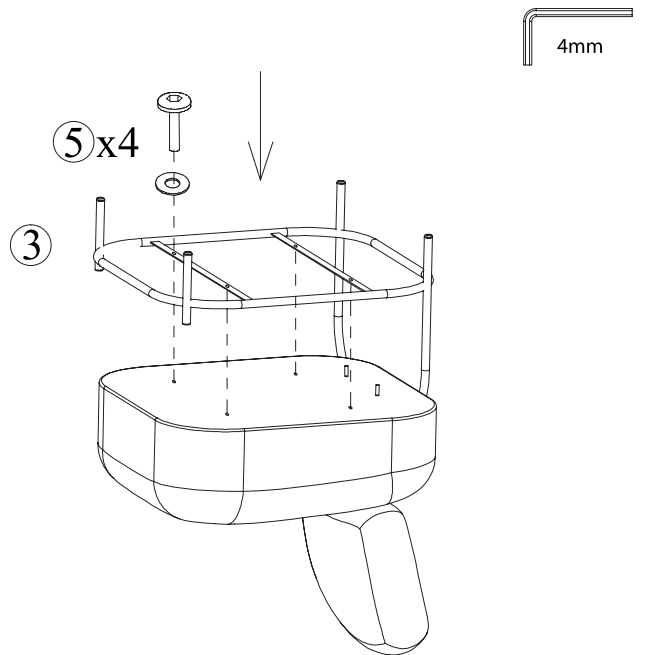

3

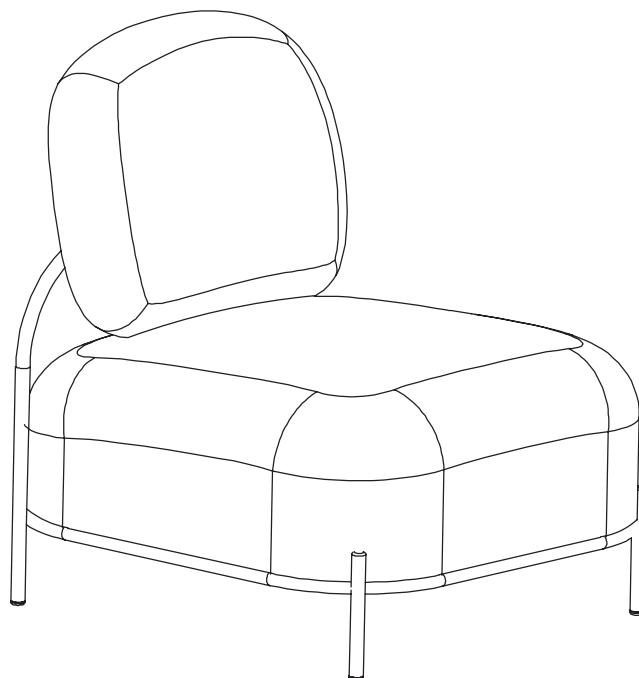

ES

INFORMACIÓN

Lea todas las instrucciones antes de comenzar el ensamblaje. Guarde las instrucciones para uso futuro.

SUGERENCIAS DE USO

Evitar la exposición directa y continuada a la luz solar. Uso interior.

ADVERTENCIA

Utilizar solo como se pretende.

MONTAJE

Seguir las instrucciones de montaje adjuntas.

MANTENIMIENTO

Periódicamente se deben realizar tareas de mantenimiento revisando el estado del producto. Verifique que el producto esté en buen estado y funcionando. Compruebe si hay roturas periódicamente. Retire el producto del servicio cuando se produzca alguna condición que pueda considerarse insegura.

CUIDADO Y LIMPIEZA

Limpie la unidad con un paño húmedo o una esponja con agua tibia y jabón suave. Séquelo. No use limpiadores abrasivos, blanqueadores, solventes químicos ni detergentes fuertes.

GARANTÍA

2 años de garantía limitada.

EN

INFORMATION

Read all instructions before beginning assembly. Keep the instructions for future use.

USAGE SUGGESTIONS

Avoid continuous exposing the product to sunlight. Indoor use.

WARNING

Use only as intended.

ASSEMBLY

Follow the attached assembly instructions.

MAINTENANCE

Periodic maintenance tasks should be performed by checking the condition of the product. Ensure the product is in good condition and functioning properly. Check for breaks regularly. Remove the product from service when any condition that could be considered unsafe occurs.

CARE AND CLEANING

Clean the unit with a damp cloth or sponge using warm water and mild soap. Dry thoroughly. Do not use abrasive cleaners, bleach, chemical solvents, or strong detergents.

WARRANTY

2-year limited warranty.

FR

INFORMATIONS

Lisez toutes les instructions avant de commencer l'assemblage. Conservez les instructions pour une utilisation future.

CONSEILS D'UTILISATION

Eviter l'exposition directe et continué à la lumière solaire. Usage intérieur.

AVERTISSEMENT

Utiliser uniquement comme prévu.

ASSEMBLAGE

Suivez les instructions de montage ci-jointes.

ENTRETIEN

Des tâches d'entretien périodiques doivent être effectuées en vérifiant l'état du produit. Assurez-vous que le produit est en bon état et fonctionne correctement. Vérifiez régulièrement s'il y a des bris. Retirez le produit du service lorsqu'une condition pouvant être considérée comme dangereuse se présente.

ENTRETIEN ET NETTOYAGE

Nettoyez l'unité avec un chiffon humide ou une éponge à l'eau tiède et au savon doux. Séchez soigneusement. N'utilisez pas de nettoyants abrasifs, d'eau de Javel, de solvants chimiques ou de détergents puissants.

GARANTIE

Garantie limitée de 2 ans.



Para posibles futuras actualizaciones del documento, visita este enlace QR para ver la última versión.

For possible future updates to the document, visit this QR link to see the latest version

Pour d'éventuelles mises à jour futures du document, visitez ce lien QR pour voir la dernière version

Document Version

V1/2024

Certifications & collaborations

CALIDAD CERTIFICADA
CERTIFIED QUALITY
QUALITÉ CERTIFIÉE



MIRPLAY COLABORA CON LA ONG:
MIRPLAY COLLABORATES WITH NGO:
MIRPLAY PARTICIPE À L'ONG:

